

Vacuum Single-interlock Preaction System, Electric Release  
Self contained unit



## **FIREFLEX<sup>®</sup>VACTEC<sup>®</sup> description**

This **FIREFLEX<sup>®</sup>VACTEC<sup>®</sup>** integrated fire protection system consists of a vacuum system trim totally pre-assembled, pre-wired and factory tested. All electrical and mechanical components of the system are contained in one single unit.

Vacuum single-interlock preaction system uses closed vacuum sprinklers specified for vacuum use with vacuum sprinklers piping network. A detection network is used in parallel with the piping network. This detection network may be actuated by manual, fixed temperature, rate-of-rise temperature, smoke or other means. Detection network is designed to operate before a vacuum sprinkler fuses and gives an alarm. Because of electrical detection network, vacuum single-interlock preaction system may be used in freezing areas.

The only connections required for installation are the water supply inlet, water discharge outlet, main drain, the electrical detection and alarm connections, as well as the AC power line(s). The discharge outlet is connected to a fixed vacuum sprinklers piping network. Water is the extinguishing agent.

The integrated **FLX-PC<sup>®</sup>** vacuum pressure controller allows the release control panel to receive all appropriate alarm and supervisory signals which supervise the vacuum pressure for appropriate discharge condition. It also controls the vacuum pump operation.

The **FIREFLEX<sup>®</sup>VACTEC<sup>®</sup>** is fully tested at factory.

The maximum water pressure is 175 psi WWP (1207 kPa). The system is available in the following diameters:

- |                                      |                                      |
|--------------------------------------|--------------------------------------|
| <input type="checkbox"/> 3" (80 mm)  | <input type="checkbox"/> 6" (150 mm) |
| <input type="checkbox"/> 4" (100 mm) | <input type="checkbox"/> 8" (200 mm) |

## **Features**

- Trouble free design for safe and easy application
- Available in 4 sizes from 3" to 8" diameter
- Uses the Viking deluge valve
- Unit comes standard with its own integrated releasing control panel
- Uses the **FLX-PC<sup>®</sup>** pressure controller
- Compact, aesthetic and easy to move
- User-friendly standardized owner's manual with every unit
- Unique serial number on every unit
- Trim is fully assembled and tested at the factory
- All trims are galvanized steel, listed and approved for 175 psi (1207 kPa) service maximum
- Quick connections to water supply and drain on both sides, and vacuum sprinklers riser on top of unit, all available with grooved end or optional flanged fittings
- Shut-off valve at the outlet of the vacuum sprinklers riser for easier maintenance
- No open drain cup inside unit
- Sturdy 14 gauge steel cabinet, painted fire red with oven baked polyester powder on phosphate base
- Textured rust proof finish
- Neoprene gasket on all doors to eliminate vibrations
- Removable doors for ease of access
- Separate unlocked access hatch to emergency manual release
- Key-alike locks on all cabinet doors
- Manufactured under ISO-9001 quality control procedures

Vacuum Single-interlock Preaction System, Electric Release  
Self contained unit

## System configuration

- Vacuum Single-Interlock Preaction System, Electric Release

### Systems hydraulic limitations

The information contained herewith is for estimation and evaluation purposes only. Its use remains the responsibility of the designer.

Designers should refer to the appropriate NFPA Standards and any other applicable codes for their final design. Also refer to *FIREFLEX Systems Inc.* appropriate user manuals and to manufacturer's data sheets for additional details.

Systems limitations indicated below are nominal flow limitations.

System size		Usage Range		Piping Equivalent Lengths w/o Shut-off Valve		Piping Equivalent Lengths c/w Shut-off Valve		Drain Flow @ 175 PSIG (1207 KPA) W.P.	
in	mm	GPM	LPM	ft	m	ft	m	GPM	LPM
3	80	100 - 700	379 - 2650	55.1	16.8	66.7	20.33	762	2884
4	100	200 - 1400	757 - 5300	71.8	21.89	83.1	25.33	1597	6405
6	150	400 - 3500	1514 - 13249	109.15	33.28	122.3	37.28	1597	6405
8	200	750 - 5200	2839 - 19684	135	41.15	146.7	44.71	1597	6405

## Sequence of operation

### Preaction operation

1. Water supply pressure is trapped in the priming chamber of the deluge valve (A1). The pressure in the priming chamber holds the deluge valve clapper closed.
2. The vacuum is maintained under the system piping by the operation of an integrated vacuum pump.
3. The activation of the detection condition alone will activate the solenoid valve (F1) and depressurize the priming chamber of the deluge valve. It will cause the deluge valve to open. The alarm pressure switch (C1) will activate. The water flow signal will be present. The water will enter the system piping.
  - Detection condition is in single zone. The operation of at least one detector in the protected area is required to fulfill the detection condition.
  - Detection condition is in crossed zones. The operation of at least one detector from each detection zone in the protected area is required to fulfill the detection condition.
4. The further opening of an automatic vacuum sprinkler will allow water to flow out of any open vacuum sprinklers.
5. The opening of an automatic vacuum sprinkler alone will not open the deluge valve. The deluge valve will remain closed. A high vacuum supervisory signal will be present.
6. The manual operation of the emergency release valve (B10) will depressurize the priming chamber of the deluge valve. This will cause the deluge valve to open.
7. The opening of the deluge valve will allow water to enter the system piping. The alarm pressure switch (C1) will activate. The water flow signal will be present. The water will flow out of any open vacuum sprinklers.

Vacuum Single-interlock Preaction System, Electric Release  
 Self contained unit

## Standard equipment

### Releasing control panel

- 120 VAC / 60 Hz, 165VA
- 240 VAC / 50 Hz, 185VA
- 12VDC / 18Ah batteries (factory installed)

The releasing control panel integrated into the **FIREFLEX<sup>®</sup> VACTEC<sup>®</sup>** cabinet is Viking's Model **VFR-400**. This panel offers four Class B, programmable detection zones (optional Class A); two Class B supervisory zones and four Class B, programmable output circuits. Some of these circuits are required for the operation of the Vacuum Single-interlock Preaction System; the others are available to the customer.

The releasing control panel is compatible with many types of fire alarm & supervisory devices such as linear heat detectors, spot-type heat and smoke detectors, water flow and release indicators, low and high air pressure switches, manual pull stations.

The releasing control panel is provided with menu driven programming, including a specific program assigned at the factory for the appropriate configuration of the system. It includes an alphanumeric display with 2 lines of 16 characters describing all the system conditions, as well as a set of red and yellow LED lamps individually indicating each of the alarm, supervisory and trouble conditions of the system.

Easy to operate control buttons are provided to activate and operate the system's various functions.

### Releasing circuit disconnect switch

The releasing circuit disconnect switch is used to disable the releasing solenoid. When the key is set to **DISABLE**, the releasing solenoid will be disconnected from the releasing control panel's releasing circuit, causing a supervisory signal and preventing accidental discharge during maintenance or inspection.

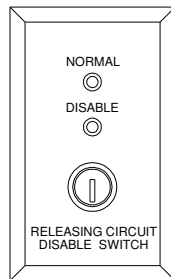

FM-076Z-0-2A

### Deluge valve

The Viking Model F-1 Deluge Valve is a quick-opening, differential diaphragm flood valve with one moving mechanism. The deluge valve is used to control water flow in vacuum sprinkler systems. The valve is held closed by system water pressure trapped in the priming chamber, keeping the outlet chamber and system piping dry. In fire conditions, when the releasing system operates, pressure is released from the priming chamber. The deluge valve clapper opens to allow water to flow into the system.

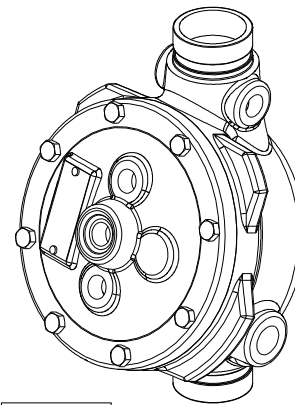

FM-076Z-0-3A

### Water supply control valve

The water inlet control valve is a supervised, indicating butterfly valve. Purpose of this valve is to manually shut-off the vacuum preaction system.

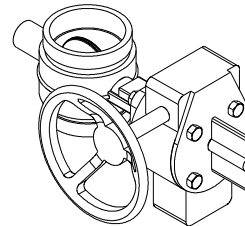

FM-076Z-0-3A

Vacuum Single-interlock Preaction System, Electric Release  
 Self contained unit

## Standard equipment (continued)

### Solenoid valve

The high pressure solenoid valve is a two-way type with one inlet and one outlet. It is a pack less, internal pilot operated valve, suitable for use in releasing water pressure from the priming chamber of Viking deluge valve. The solenoid valve has floating diaphragm construction, which requires a minimum pressure drop across the valve to operate properly.

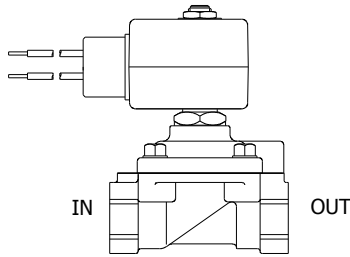

FM-076Z-0-3A

### Alarm pressure switch

The alarm pressure switch monitors the water flow within the vacuum sprinkler piping. Should the deluge valve clapper opens to allow water to flow into the sprinkler piping, the alarm pressure switch will activate, indicating a water flow signal.



FM-076Z-0-3A

### FLX-PC<sup>®</sup> vacuum pressure controller

The **FLX-PC<sup>®</sup>** vacuum pressure controller monitors the vacuum pressure inside the vacuum sprinklers piping network and control the vacuum pump to maintain the appropriate vacuum pressure. Alarm and supervisory signals are transmitted to the release control panel upon pre-settled vacuum pressure levels. An alphanumeric display shows the vacuum pressure status. A single-button control allows the user to view history and set some parameters.

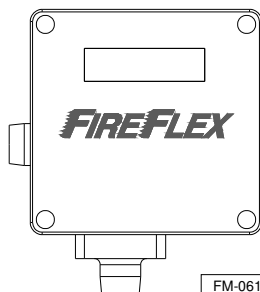

FM-061H-0-267A

### Shut-off valve & sight glass

The shut-off valve & sight glass are intended to be used for applications where testing of the system operation without filling the sprinkler piping network is desirable and where it is critical that all functions of the vacuum preaction system be tested under actual discharge conditions.

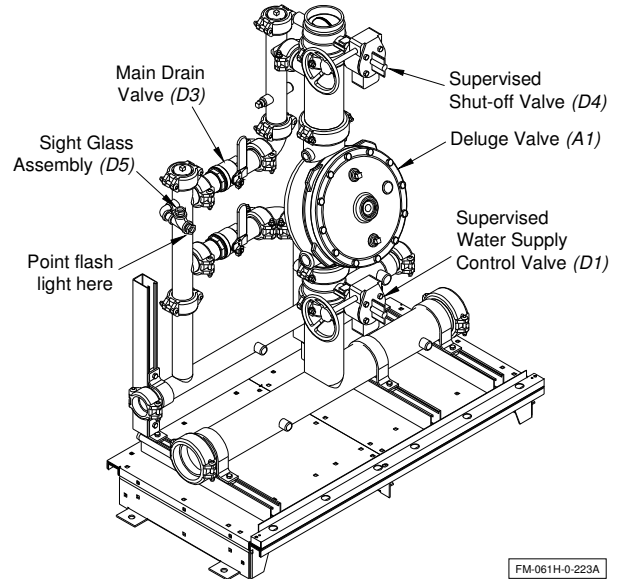

FM-061H-0-223A

Vacuum Single-interlock Preaction System, Electric Release  
Self contained unit

## Optional equipment

### □ Semi-flange and full-flange inlet / outlet (optional)

When required by the user, **FIREFLEX<sup>®</sup> VACTEC<sup>®</sup>** unit can be provided in a semi-flanged or full-flange configuration.

The semi-flanged option provides flanged fittings only on the water inlet pipe (side needs to be specified at the time of order) and on the system riser outlet. The drain manifold is provided with a threaded end that also needs to have its side specified (left or right). The rest of the fittings are the same as usual with the main components being provided in the standard flanged/grooved configuration.

The full-flanged option is the same as above but goes a step further with the main components being also provided with a flanged/flanged configuration.

When provided, the face of the flanges will always be located 6 inches (150mm) from the outside face of the mounting base or cabinet surface.

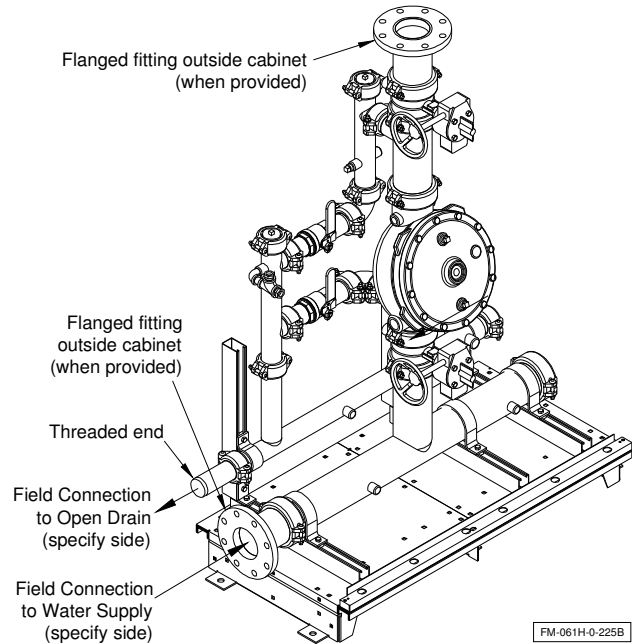

Vacuum Single-interlock Preaction System, Electric Release  
Self contained unit

## Vacuum supply

### Vacuum supply description

Vacuum sprinkler system uses negative vacuum pressure to supervise the piping network. The vacuum supply is provided within the **FIREFLEX<sup>®</sup>VACTEC<sup>®</sup>** unit. The vacuum supply trim is factory assembled in the system cabinet, calibrated and pressure tested.

The vacuum supply system trim includes a liquid ring vacuum pump (*G1*), all regulating devices to control flow of water and pump motor shut off electrical components.

The vacuum pump power requirement is specified at 220/240VAC, 50/60Hz, 1.5 HP, 1 phase.

The vacuum pump is able to establish the total required vacuum pressure in less than 30 minutes for system capacity up to 4000 gallons.

All pressure settings are factory set and do not need further calibration unless malfunction.

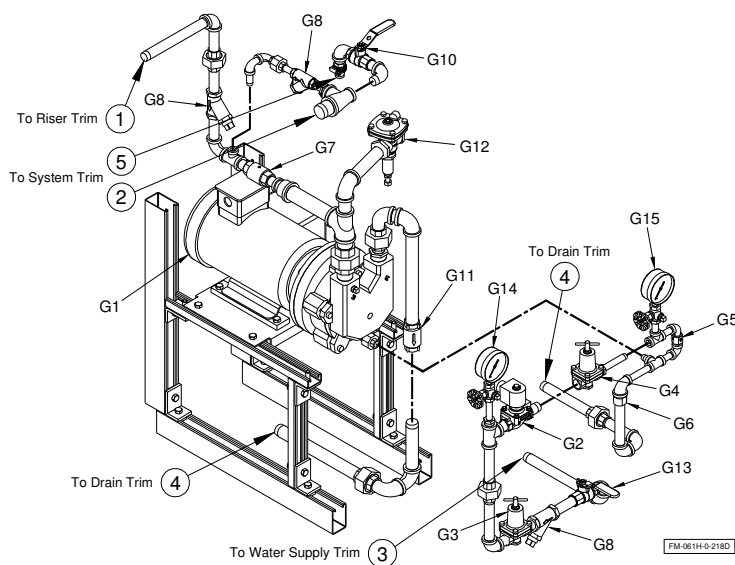

### Vacuum pump components:

- |                                |   |
|--------------------------------|---|
| G1 Liquid ring vacuum pump     | G10 System drain valve (N.C.)           |
| G2 240 VAC N.C. solenoid valve | G11 Reversed check valve                |
| G3 Pre-regulator               | G12 Vacuum breaker valve                |
| G4 Fine-adjust regulator       | G13 Water ring cut-off valve (N.O.)     |
| G5 0.125" restricted orifice   | G14 Pre-regulator gauge & valve         |
| G6 Float check valve           | G15 Fine-adjust regulator gauge & valve |
| G7 2-way check valve           |   |
| G8 Strainer                    |   |

Vacuum Single-interlock Preaction System, Electric Release  
 Self contained unit

## Details & field wiring diagrams

### Main hydraulic components

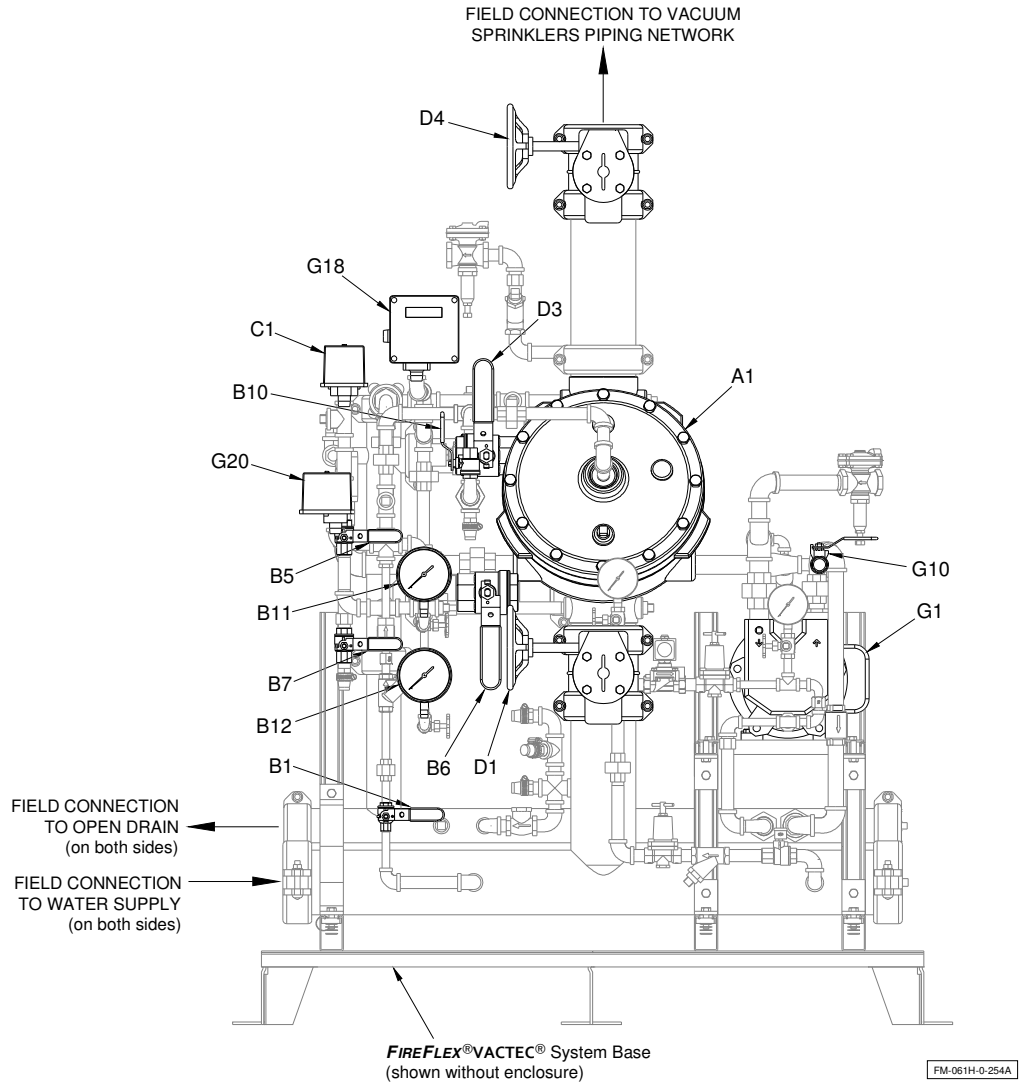

Vacuum Single-interlock Preaction System, Electric Release  
Self contained unit

**Trim Diagram**

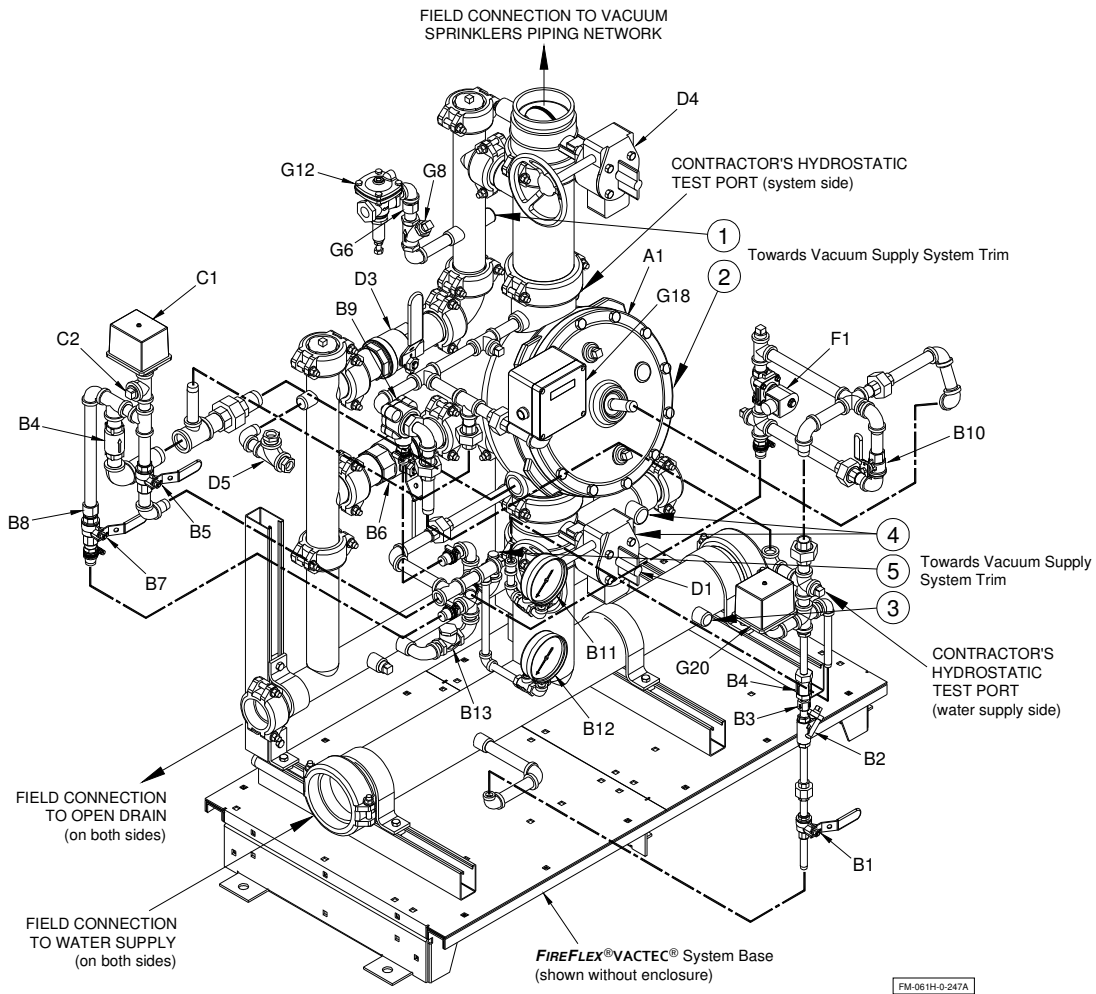

**Trim Components:**

- |     |   |     |  |
|-----|---|-----|--|
| A1  | Deluge valve                                | C1  | Alarm pressure switch (PS10-1A)  |
| B1  | Priming valve (N.O.)                        | C2  | 3/4"-NPT (20mm) Connection to water motor gong (strainer supplied by contractor) |
| B2  | Strainer                                    | D1  | Water supply control valve (N.O.)  |
| B3  | 1/16" Restricted orifice                    | D3  | Main drain valve (N.C.)  |
| B4  | Spring loaded check valve                   | D4  | Shut-off- valve (N.O.)   |
| B5  | Alarm test valve (N.C.)                     | D5  | Sight glass assembly   |
| B6  | Flow test valve (N.C.)                      | F1  | 24VDC N.C. Solenoid valve  |
| B7  | Alarm line drain valve (N.C.)               | G6  | Vacuum pump drain float check  |
| B8  | 1/8" Restricted orifice                     | G8  | Vacuum pump network strainer   |
| B9  | PORV (pressure operated relief valve)       | G12 | Vacuum breaker valve   |
| B10 | Manual emergency release valve (N.C.)       | G18 | <b>FLX-PC®</b> Vacuum pressure controller  |
| B11 | Priming pressure water gauge & valve (N.O.) | G20 | Vacuum pump control pressure switch (PS40-1A)                                    |
| B12 | Water supply pressure gauge & valve (N.O.)  |     |  |
| B13 | Clapper check valve                         |     |  |



Vacuum Single-interlock Preaction System, Electric Release  
 Self contained unit

### Control Panel and Vacuum Pump Control Layout

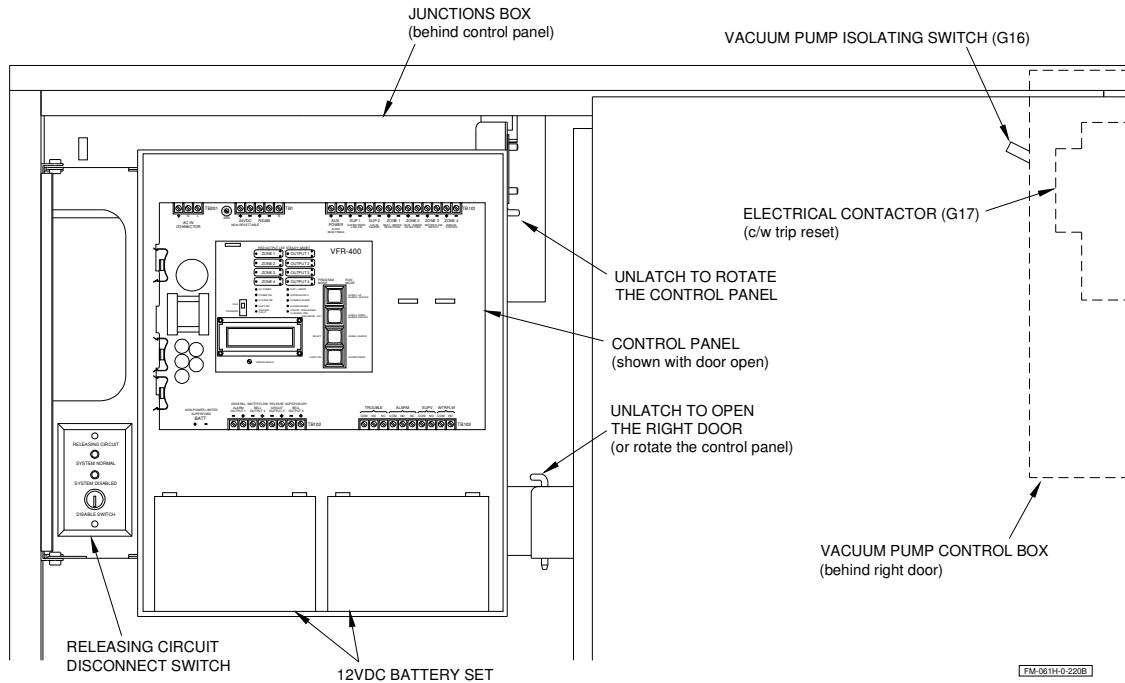

### Junctions Box Layout

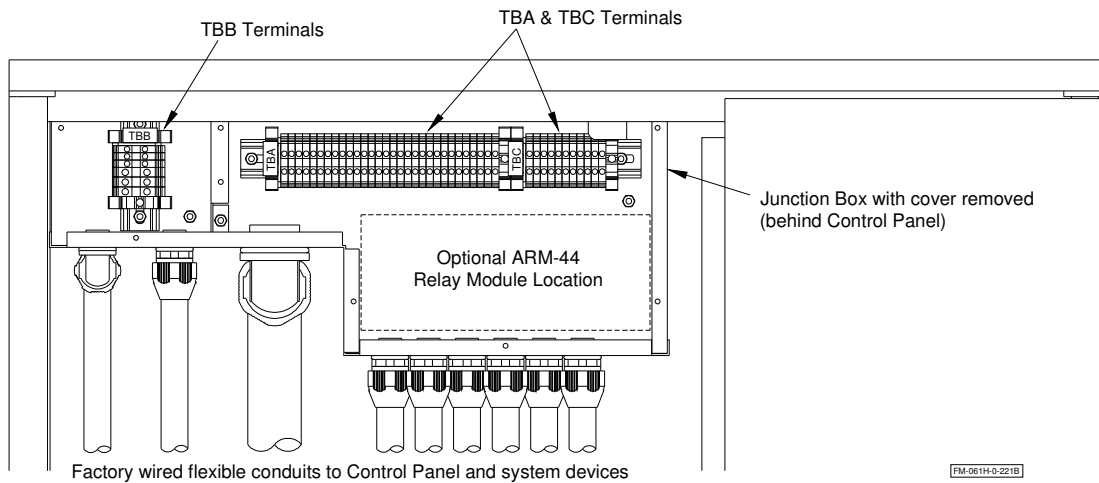

## Vacuum Single-interlock Preaction System, Electric Release Self contained unit

### Wiring diagram

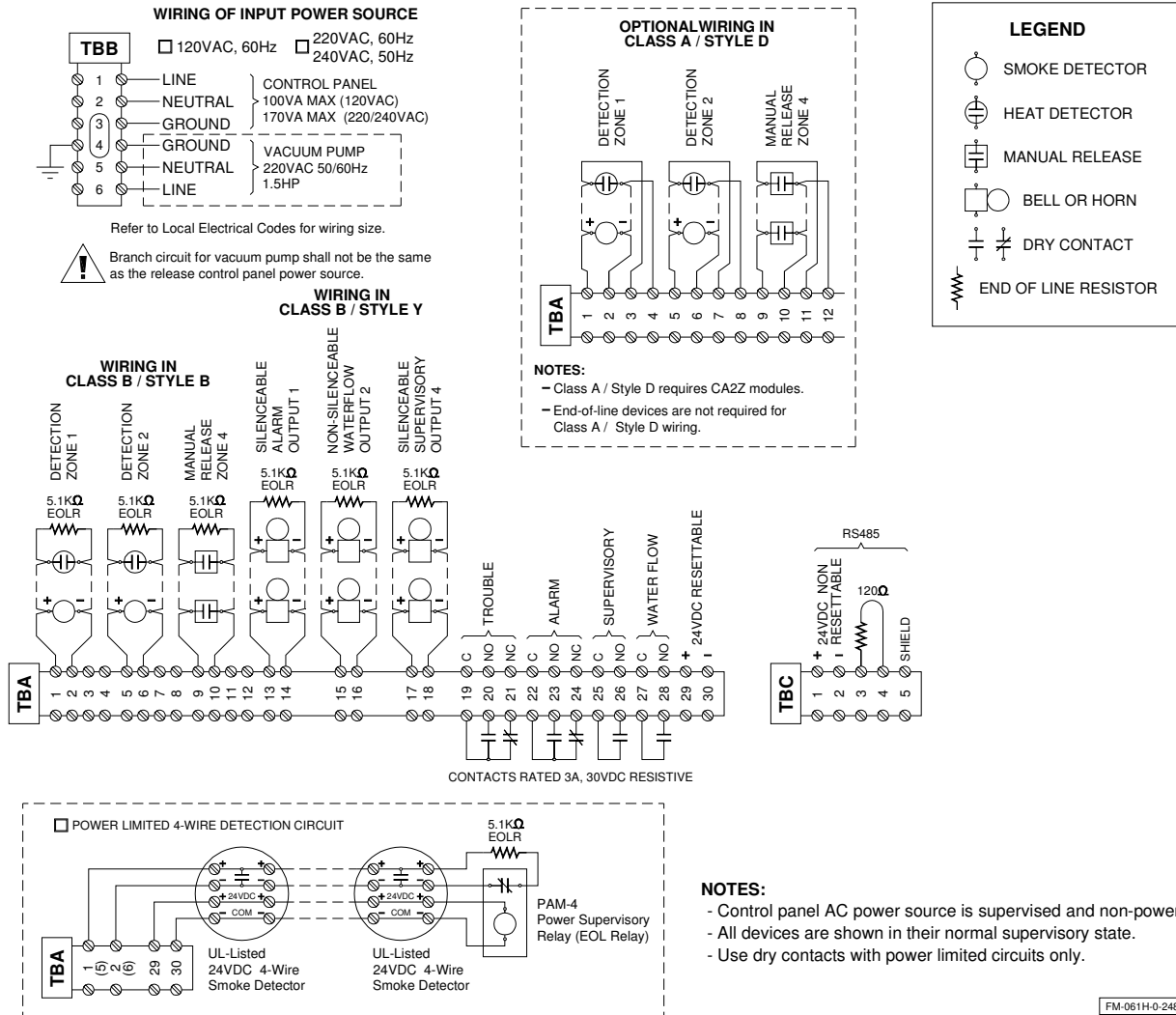

### Power Limited (supervised) Initiating Device Circuits

Zones 1 (detection), 2 (detection) and 4 (manual release):

Class B or optional Class A

Max. loop resistance: 100 ohms

End of line: 5.1K ohms, 1/4W

Leave ELR (provided) on all unused circuits.

Refer to Device Compatibility in the VFR-400 Releasing control panel Manual.

### Auxiliary Power 24Vdc Regulated Source

Total current available: 0.2A

Resettable for 4 wires smoke detectors

### Power Limited (supervised) Notification Appliance Circuits

Output Circuit 1, 2 and 4:

Maximum operating voltage: 27Vdc (ripple: 0.3Vdc)

Maximum usable current per circuit: 1.0A

Total current available (all circuits): 2.5A

Polarity is reversed in supervisory condition.

Leave ELR (provided) on all unused circuits.

Refer to Device Compatibility in the VFR-400 Releasing control panel Manual.

**WARNING** Releasing control panel shall be supplied by a dedicated circuit breaker, as per NFPA 70, Section 760 and Canadian Electrical Code, Section 32.

Vacuum Single-interlock Preaction System, Electric Release  
 Self contained unit

## Cabinet

The **FIREFLEX<sup>®</sup> VACTEC<sup>®</sup>** unit cabinet is made of sturdy 14 gauge steel, it is available in two (2) sizes:

- 46" x 25" x 77" (1170mm x 640mm x 1960mm) for 3", 4" or 6" system
- 54" x 31" x 81" (1370mm x 790mm x 2060mm) for 8" system

All external and internal surfaces are rust proof coated, inside and outside, with fire red, oven baked polyester powder on phosphate base. Cabinet is provided with two doors, both provided with a neoprene gasket to absorb vibrations.

The cabinet unit is pre-assembled, pre-wired, and factory tested under ISO-9001 specifications. Each cabinet door is provided with hinges that can be disassembled on site to remove the door assemblies for servicing.

Gauges to indicate water supply pressure, priming water pressure and vacuum pressure are all visible through clear Lexan windows.

The release control panel of the **FIREFLEX<sup>®</sup> VACTEC<sup>®</sup>** system is installed inside the cabinet at the factory. The field wiring electrical junction boxes is integrated with the cabinet for connection of applicable detection system, auxiliary contacts and signaling devices. All inputs & outputs are factory wired to a terminal strip (TBA) for contractor's field wiring.

**Figure 1 - Floor anchoring template**

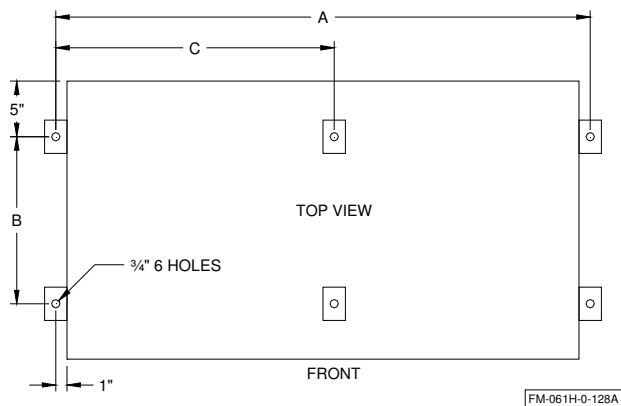

Unit size	3"	4"	6"	8"
<b>A</b>	48" 1220mm	48" 1220mm	48" 1220mm	56" 1422mm
<b>B</b>	15" 380mm	15" 380mm	15" 380mm	21" 530mm
<b>C</b>	25" 635mm	25" 635mm	25" 635mm	29" 735mm

**Figure 2 - knockouts details**

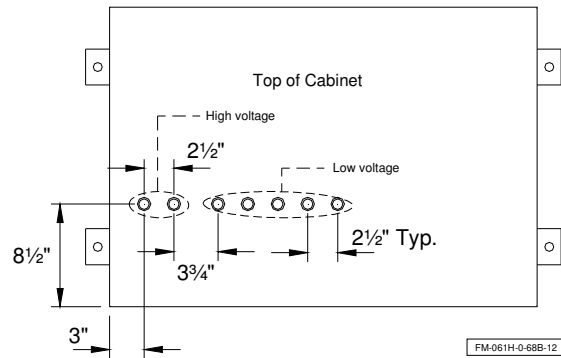

**Figure 3 - Required clearance**

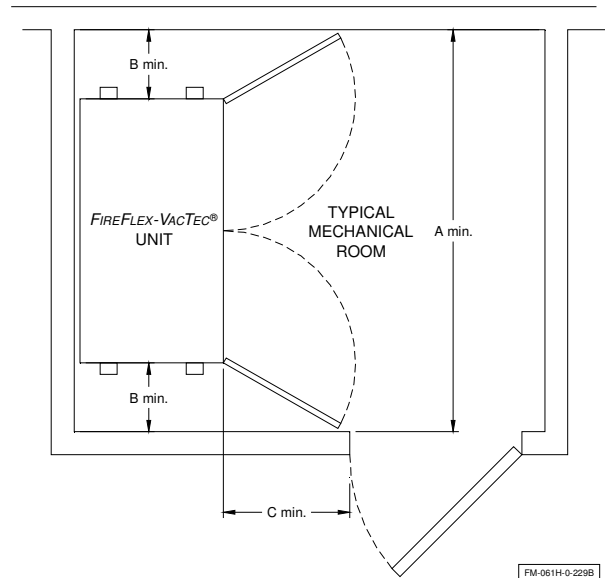

Unit size	3"	4"	6"	8"
<b>A</b>	70" 1780mm	70" 1780mm	70" 1780mm	78" 1980mm
<b>B</b>	12" 305mm	12" 305mm	12" 305mm	12" 305mm
<b>C</b>	24" 610mm	24" 610mm	24" 610mm	24" 610mm

Vacuum Single-interlock Preaction System, Electric Release  
 Self contained unit

Figure 4 - Cabinet dimensions

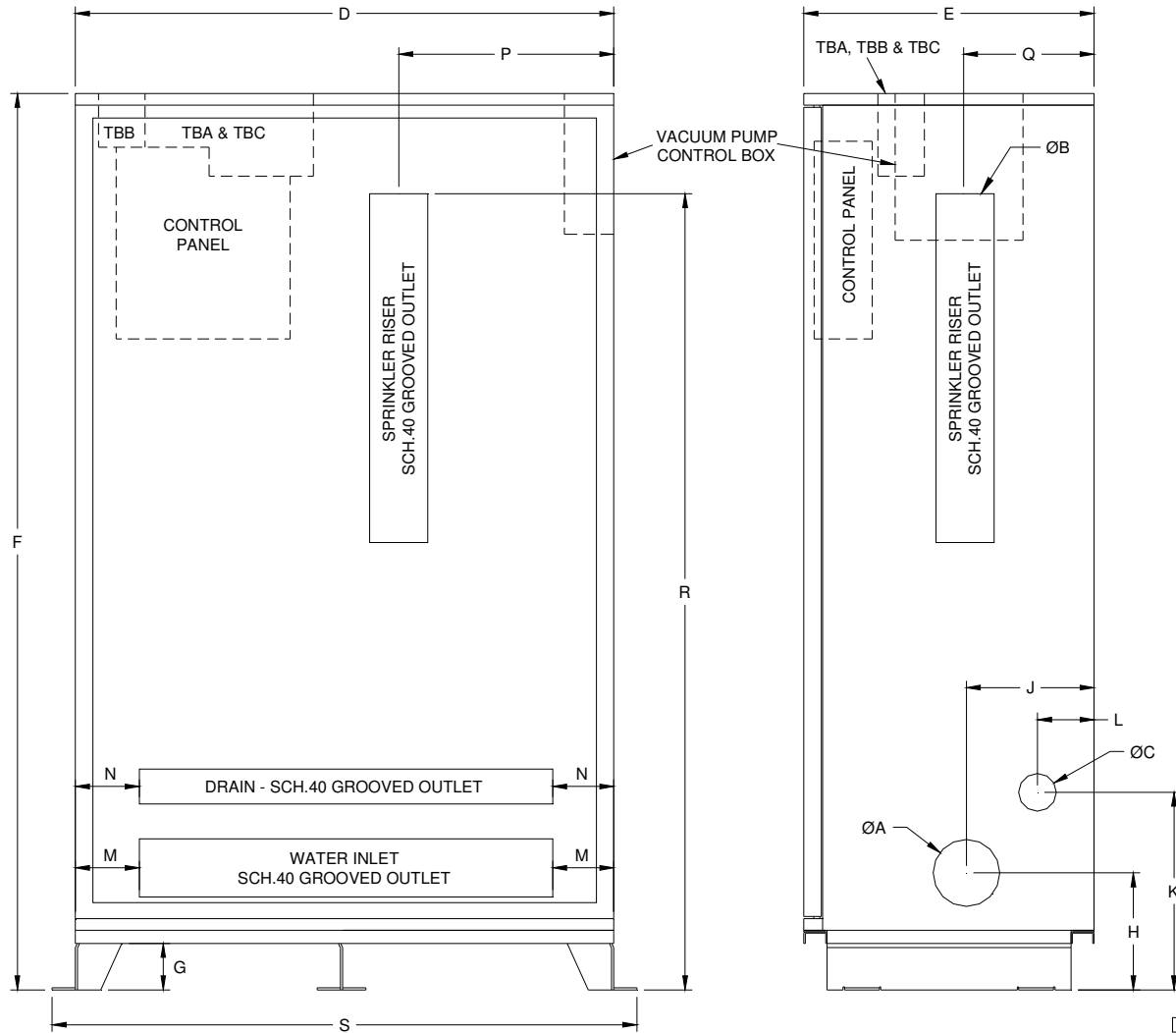

FM-061H-0-228E

Unit size	A	B	C	D	E	F	G	H	J	K	L	M	N	P	Q	R	S
3"	4" 100mm	3" 75mm	2" 50mm	46" 1170mm	25" 635mm	77" 1955mm	4" 100mm	10" 255mm	11½" 290mm	13¾" 350mm	¾" 950mm	2½" 65mm	2½" 65mm	22¼" 565mm	11½" 290mm	57¾" 1465mm	50" 1270mm
4"	4" 100mm	4" 100mm	2" 50mm	46" 1170mm	25" 635mm	77" 1955mm	4" 100mm	10" 255mm	11½" 290mm	13¾" 350mm	¾" 950mm	2½" 65mm	2½" 65mm	22¼" 565mm	11½" 290mm	62½" 1590mm	50" 1270mm
6"	6" 150mm	6" 150mm	2" 50mm	46" 1170mm	25" 635mm	77" 1955mm	4" 100mm	11" 280mm	11½" 290mm	13¾" 350mm	¾" 950mm	2½" 65mm	2½" 65mm	21¼" 540mm	11½" 290mm	64½" 1640mm	50" 1270mm
8"	8" 200mm	8" 200mm	2" 50mm	54" 1370mm	31" 785mm	81" 2055mm	4" 100mm	12" 305mm	13¼" 335mm	17½" 445mm	¾" 95mm	¾" 95mm	¾" 95mm	27" 685mm	13¼" 335mm	75½" 1920mm	58" 1270mm

Dimensions are nominal and may vary by ¼" (5mm)



# Datasheet

Vacuum Single-interlock Preaction System, Electric Release  
Self contained unit

This page is left blank intentionally.



1935, Lionel-Bertrand Blvd.  
Boisbriand QC Canada J7H 1N8  
**Tel.: 450-437-3473 • Fax: 450-437-1930**  
**Toll Free: 866-347-3353**  
**Email: [info@fireflex.com](mailto:info@fireflex.com) • Web: [www.fireflex.com](http://www.fireflex.com)**